

19427

DE	MONTAGEANLEITUNG:	PENDELTÜR, 2-TEILIG + SEITENWAND / PENDELTÜR, 2-TEILIG
GB	INSTALLATION INSTRUCTIONS:	DOOR WITH 2 PIVOT PANELS + FIXED PANEL / DOOR WITH 2 PIVOT PANELS
FR	NOTICE DE MONTAGE:	PORTE SALOON + PAROI FIXE / PORTE SALOON
CZ	NÁVOD K MONTÁŽI:	DVOUKŘÍDLÉ DVEŘE + BOČNÍ STĚNA / DVOUKŘÍDLÉ DVEŘE
PL	INSTRUKCJA MONTAŻU:	2-CZĘŚCIOWE DRZWI WAHANDŁOWE
SK	NÁVOD NA MONTÁŽ:	DVOJKRÍDLOVÉ DVEŘE + BOČNÁ STĚNA / DVOJKRÍDLOVÉ DVEŘE
RU	ИНСТРУКЦИЯ ПО МОНТАЖУ:	ДВУХСТВОРЧАТАЯ ДВЕРЬ + ФИКСИРОВАННАЯ ПАНЕЛЬ/ ДВУХСТВОРЧАТАЯ ДВЕРЬ
ES	INSTRUCCIONES DE MONTAJE:	PUERTA PIVOTANTE, 2 PIEZAS
RO	INSTRUCȚIUNI DE MONTAJ:	UȘĂ BATANTĂ, 2 PIESE + PERETE LATERAL / UȘĂ BATANTĂ, 2 PIESE

1. - 9.

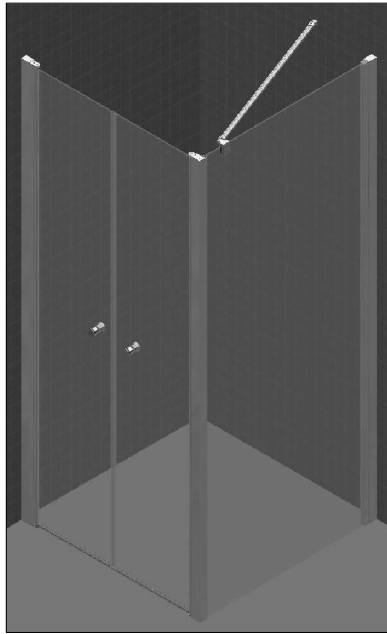

10. - 17.

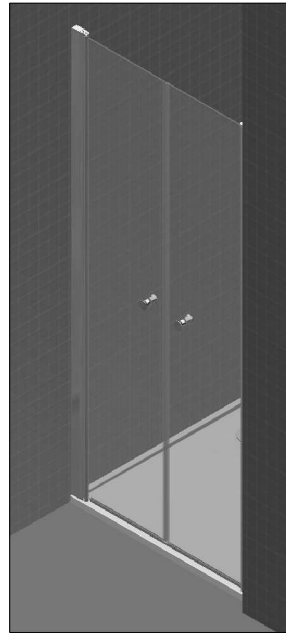

Benötigtes Werkzeug:
Necessary tools:
Outil Nécessaire:
Nářadí potřebné pro montáž:
Potrzebne narzędzia:
Potrebne náradie:
необходимые инструменты:
Herramientas necesarias:

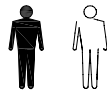

1x

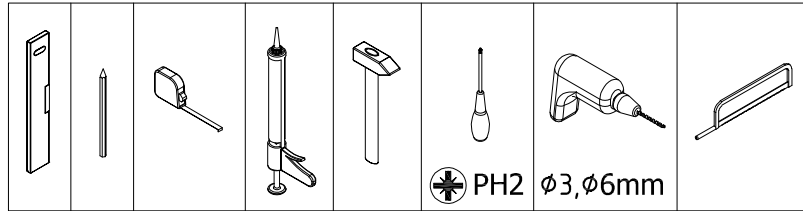

PH2 $\varnothing 3, \varnothing 6\text{mm}$

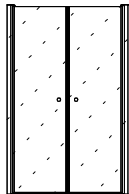

2x50007E
(50012+50007)

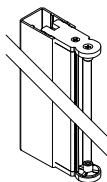

2x42356

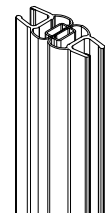

2x52203U21000.F

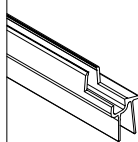

52203L

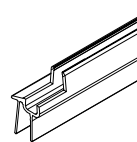

52203R

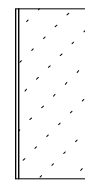
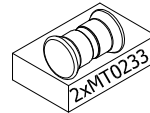

MT0324.50.xxx
(1x)

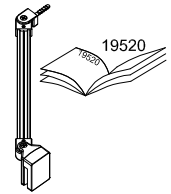

19520

Zubehör:
Equipment:
Accessoires:
Příslušenství:
Dodatki:
Príslušenstvo:
Аксессуары:
Accesorios:

	1 x 11221	2 x 51400	6 x 16000 $\varnothing 6\text{mm}$	6 x 14003 3,5x9,5mm	6x51337	6x51338
	1 x 51339	1 x 51399	3x51338	3 x 14003 3,5x9,5mm	1x51412	1 x 51439/440

1.

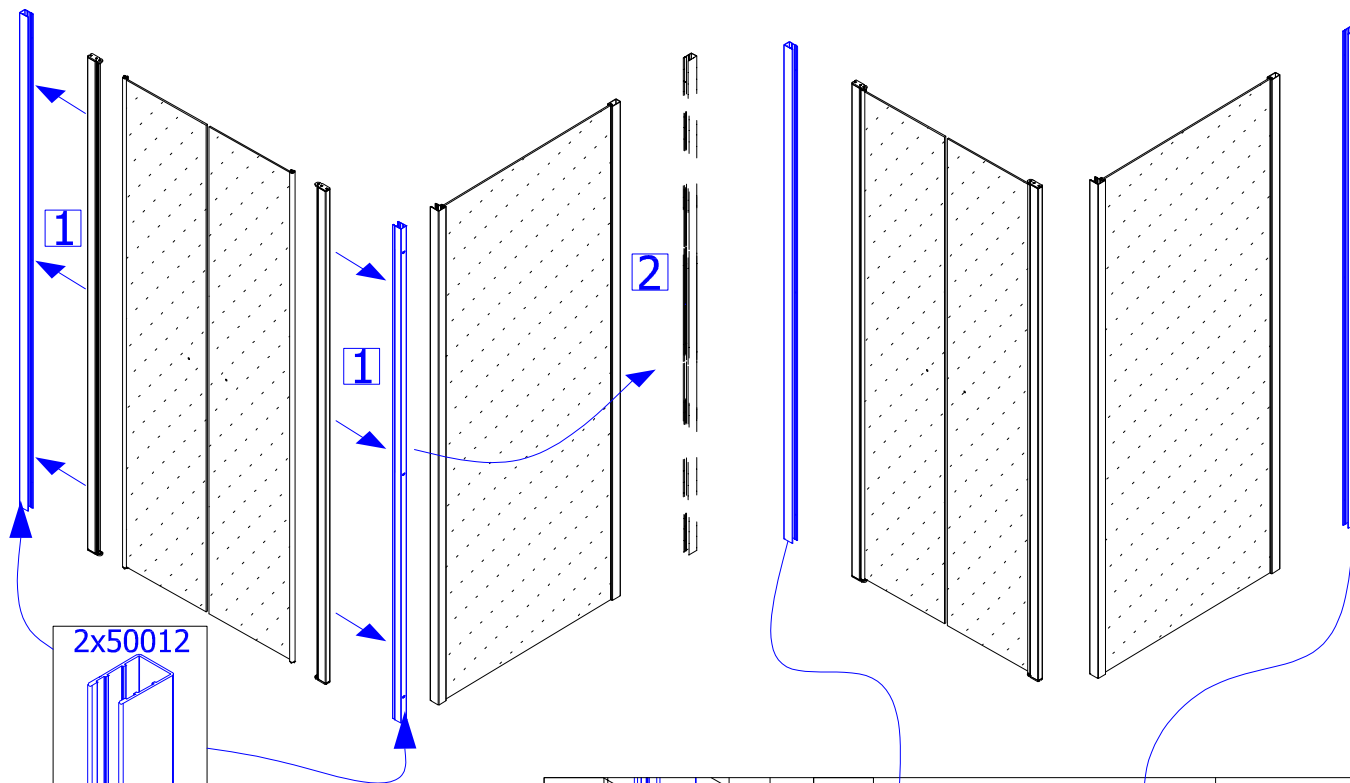

2x50012

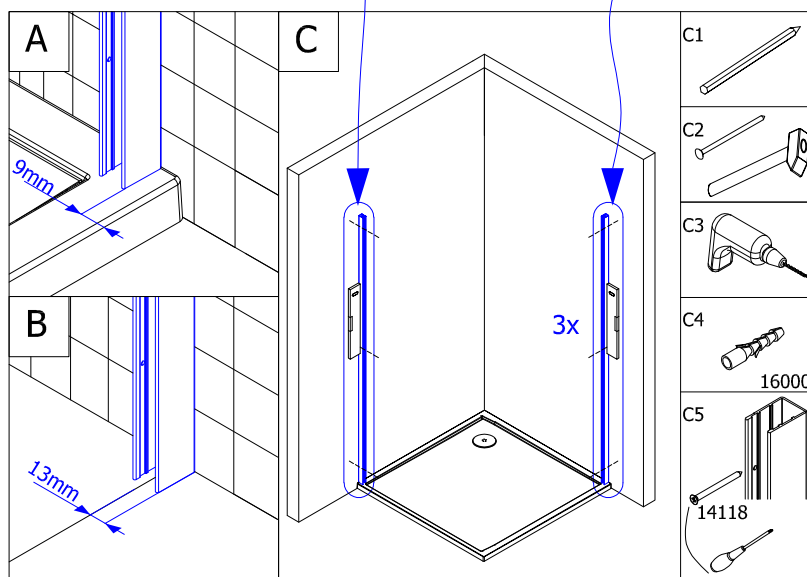
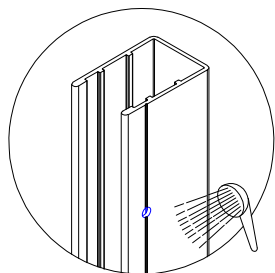

2.

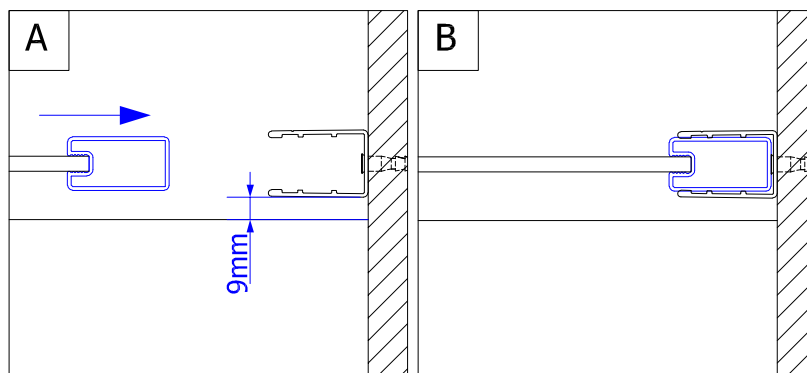
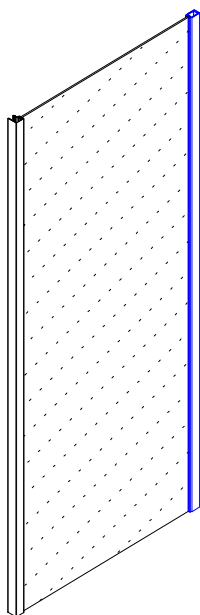

3.

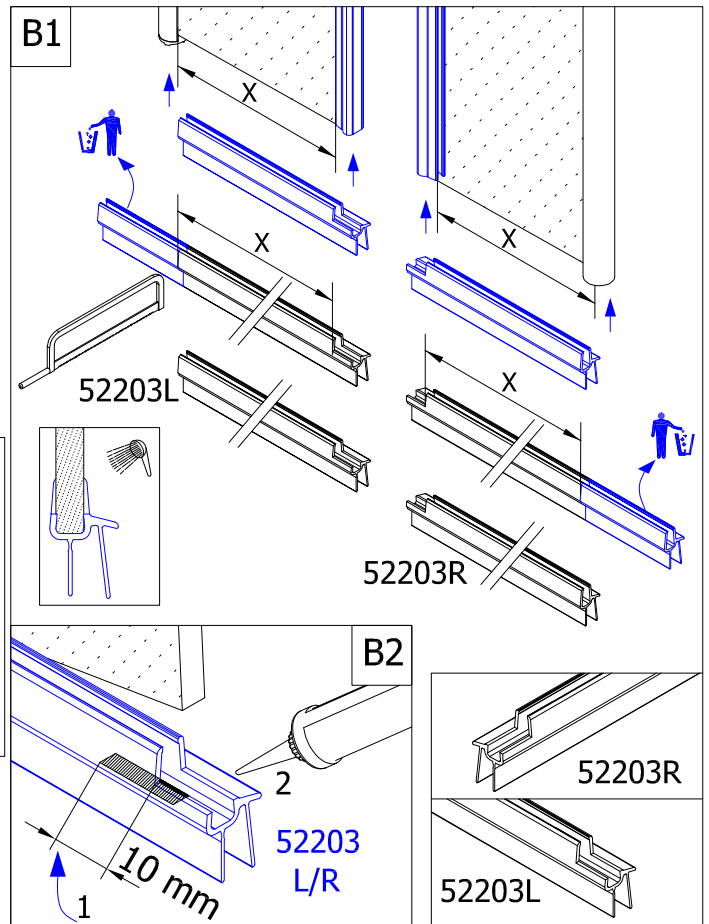
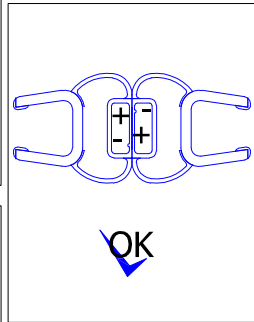
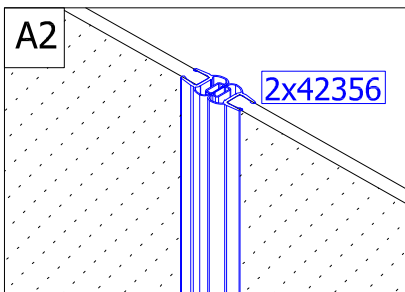
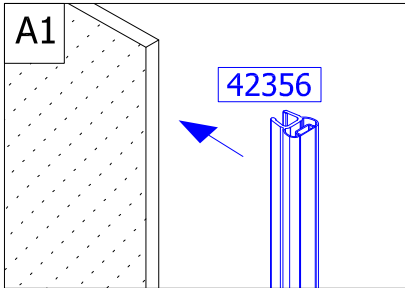
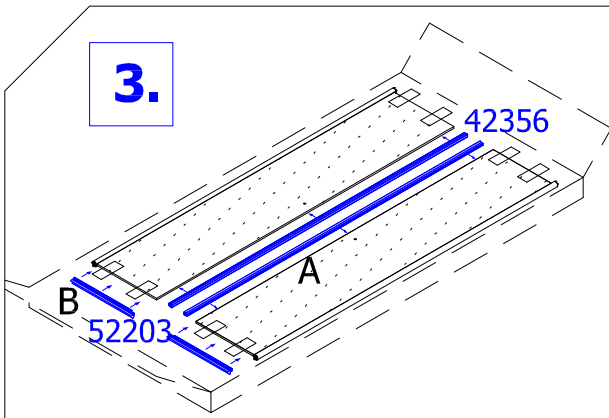

4.

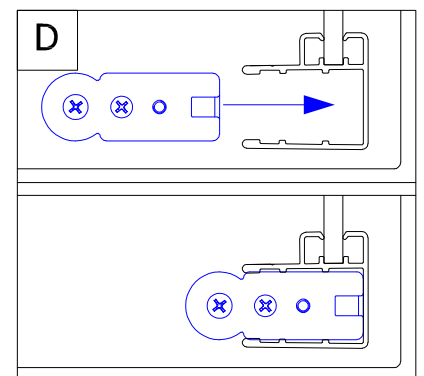
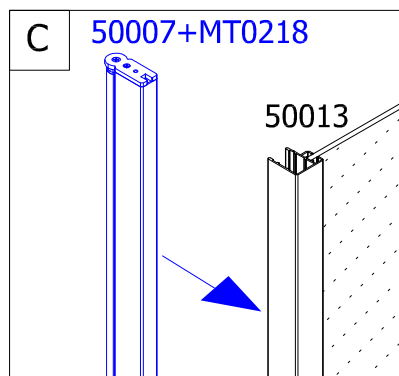
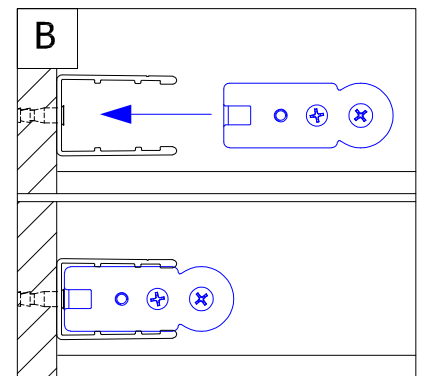
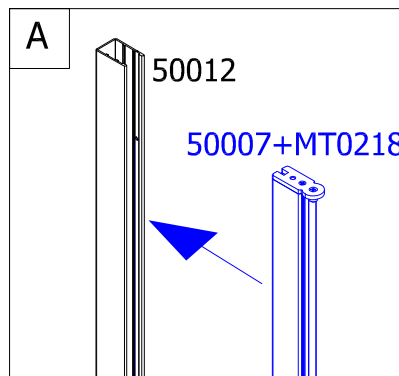
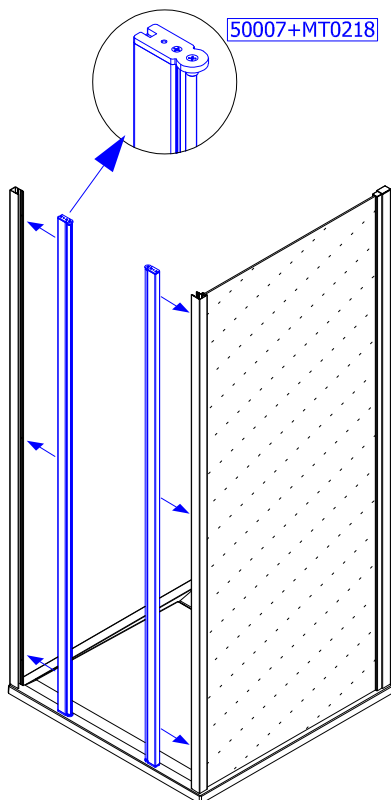

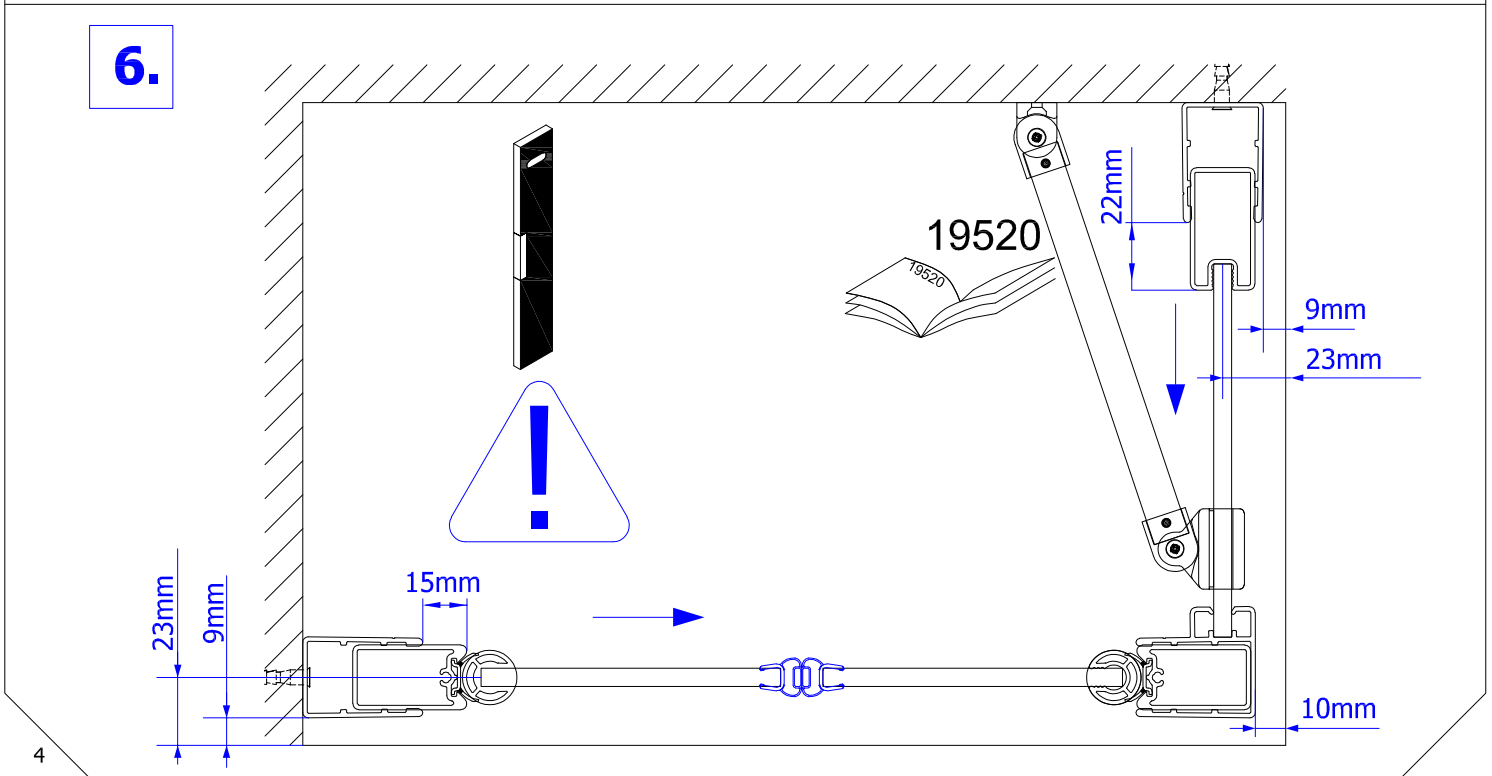
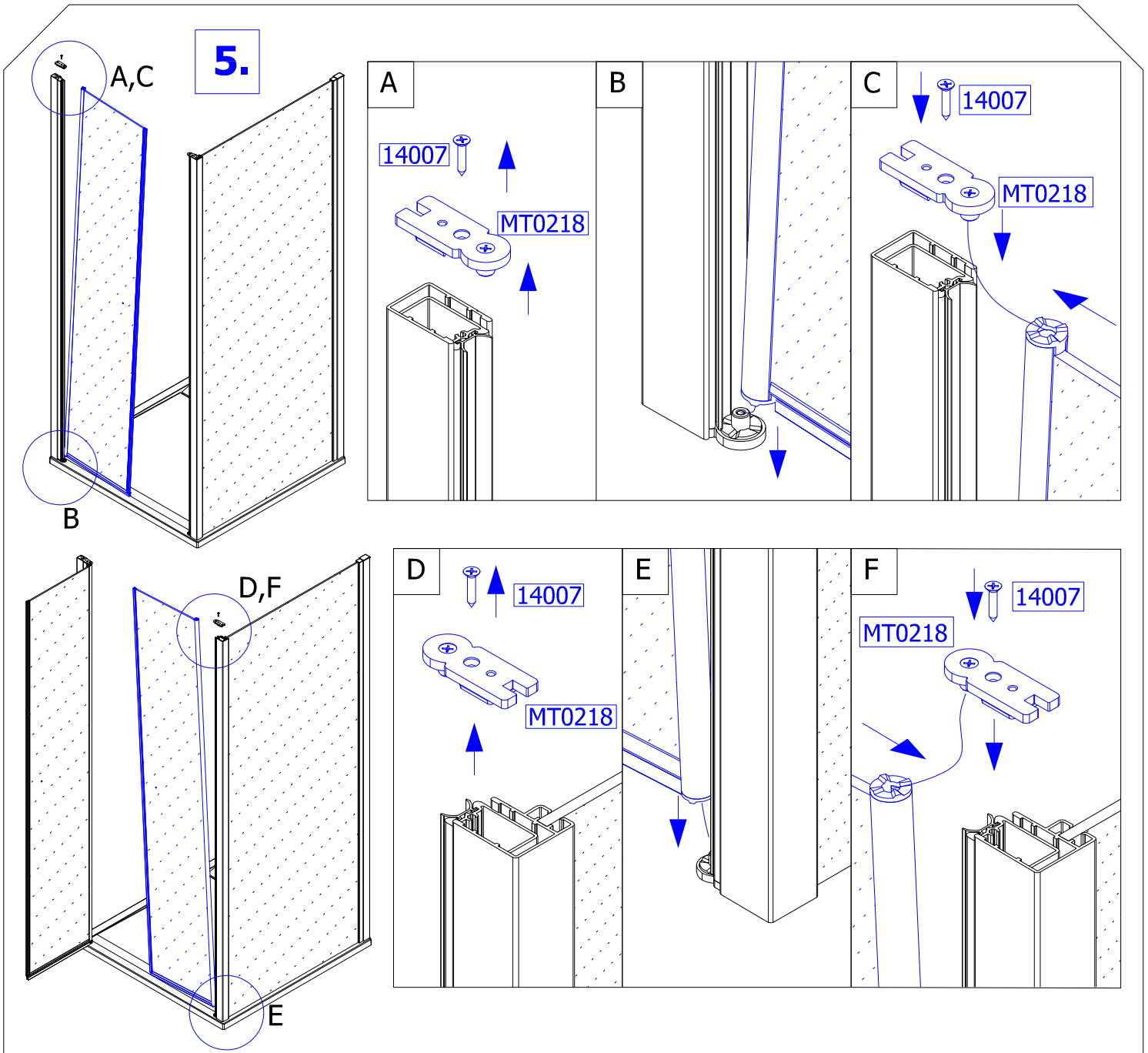

7.

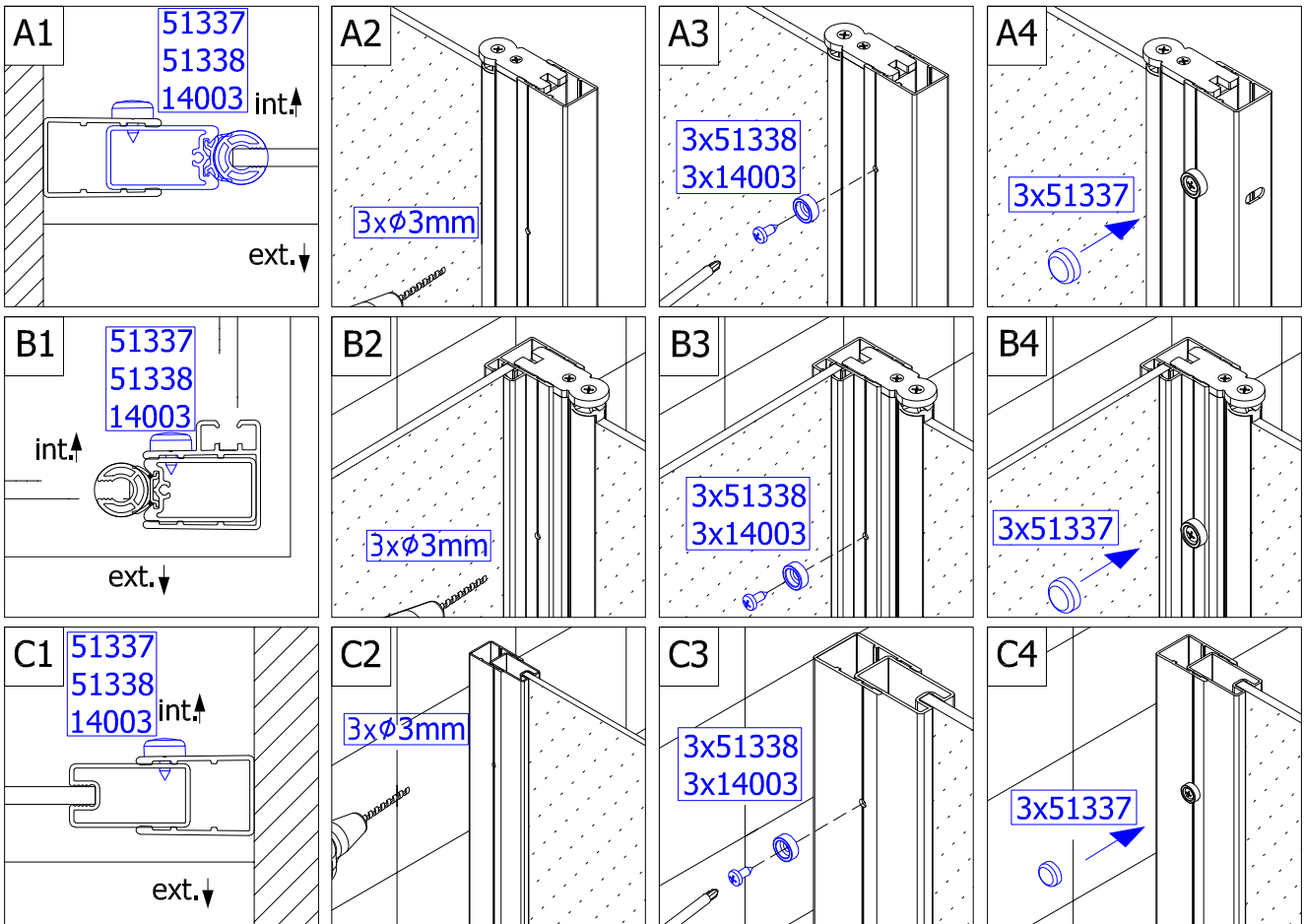
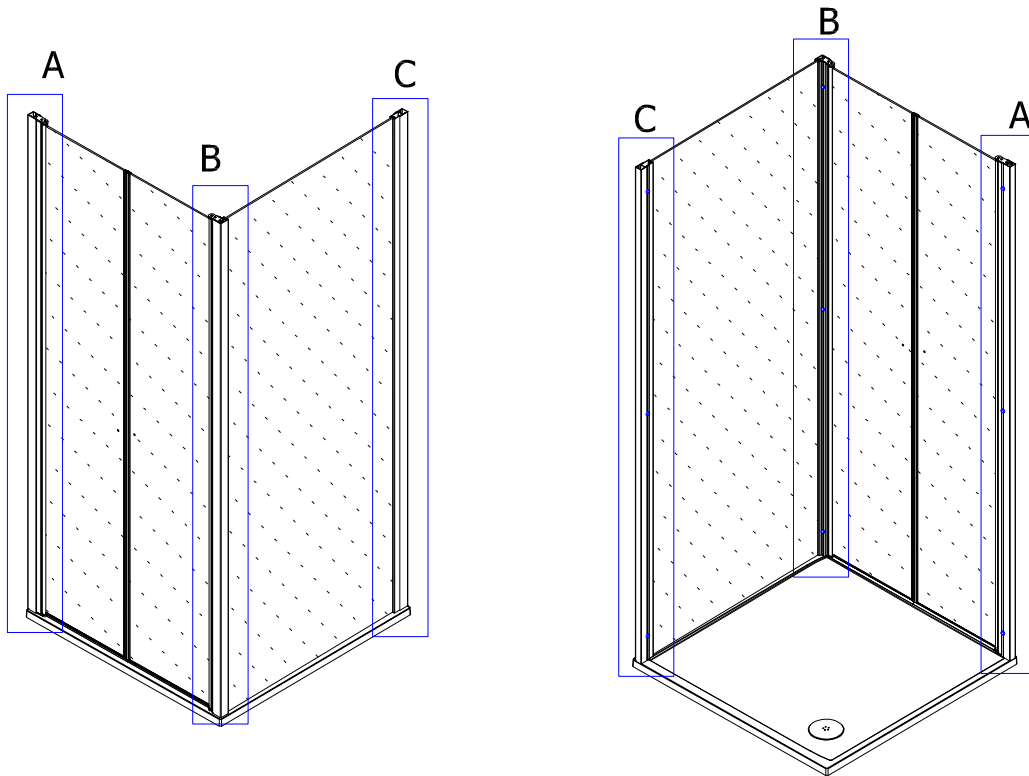

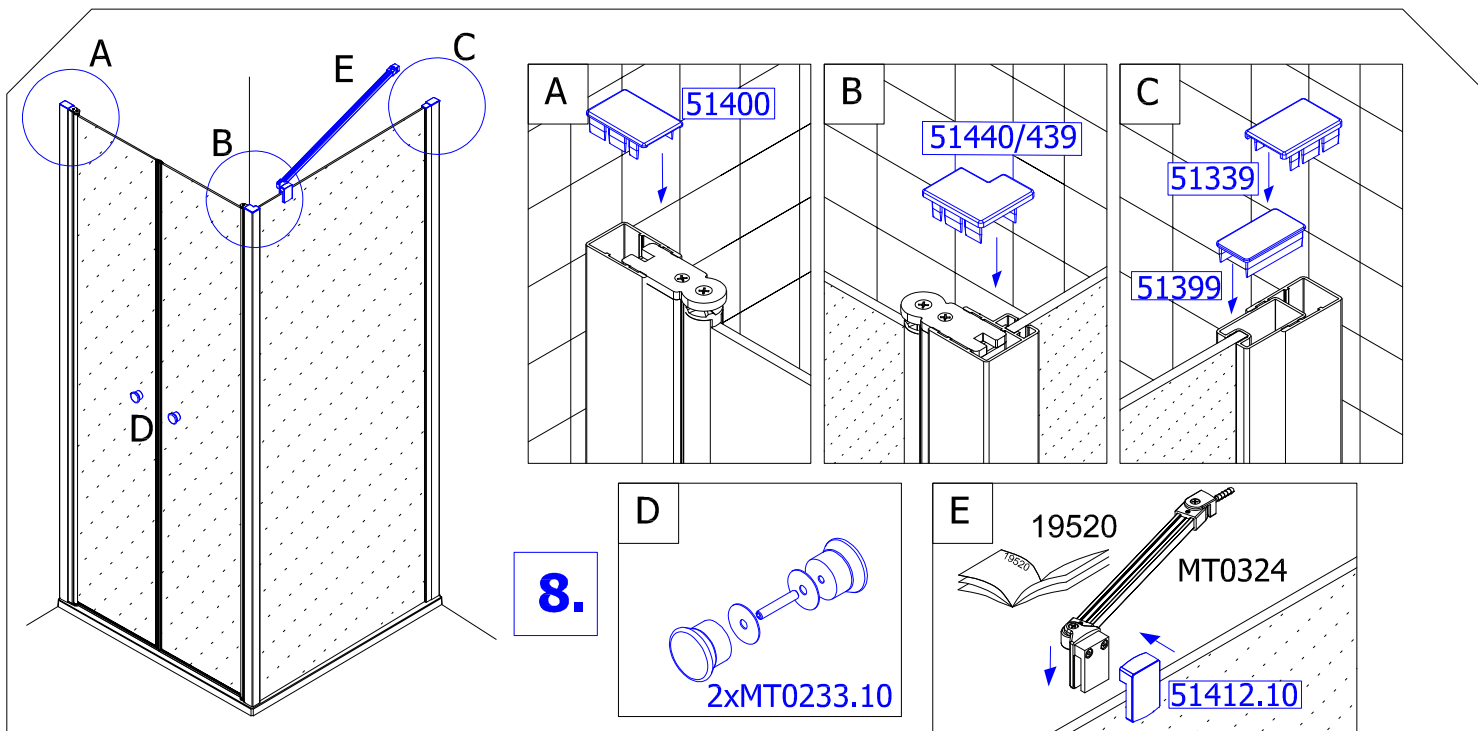

8.

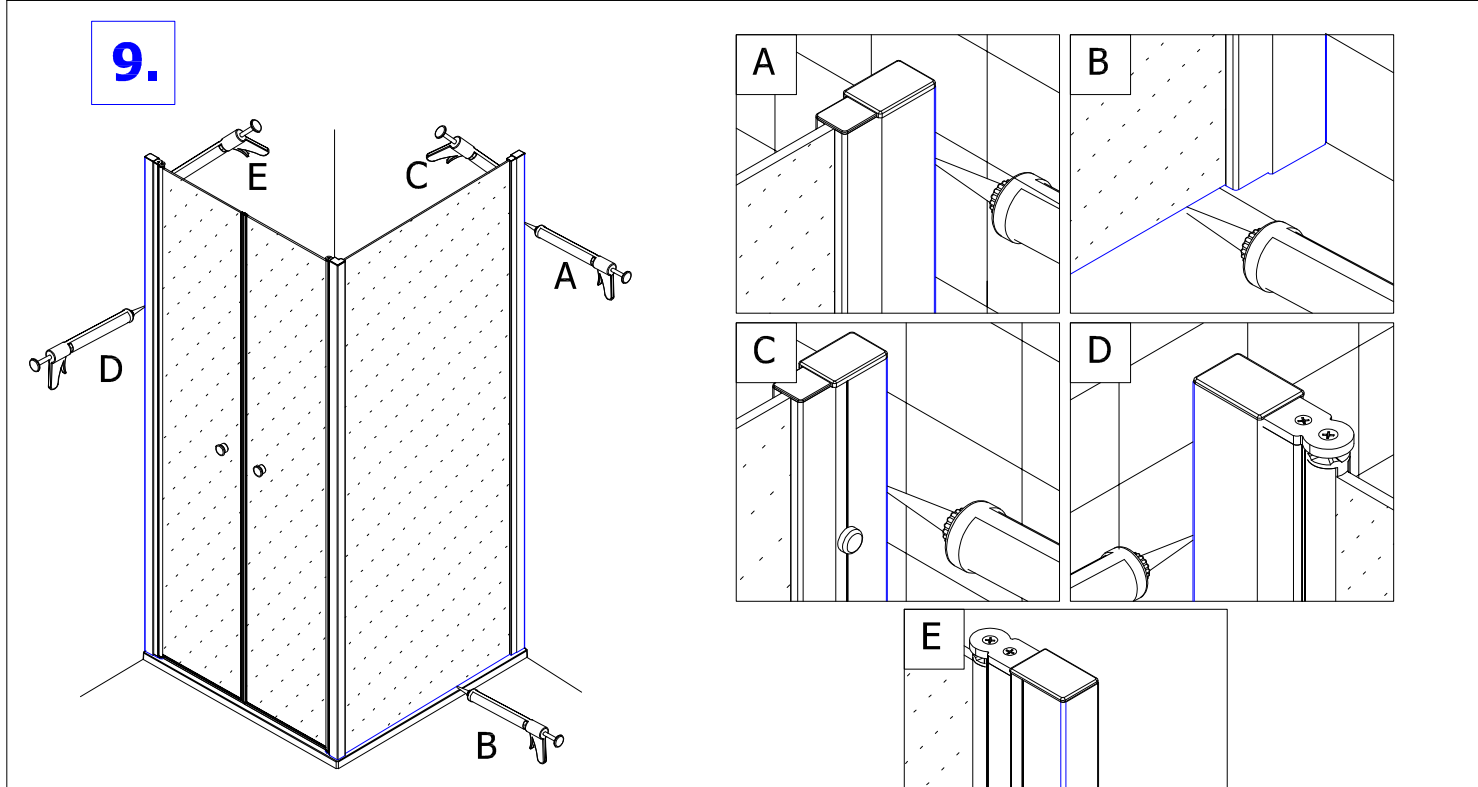

9.

Achtung! Nur Sanitär-Silikon - bakterizid und fungizid eingestellt verwenden.

Caution! Use only bactericidal and fungicide sanitary silicone.

Attention! N'utiliser que du silicone sanitaire bactéricide et fongicide.

Pozor! Používejte pouze baktericidní a fungicidní sanitární silikon.

Uwaga! Stosować tylko silikon sanitarny - bakterio i grzybobójczy.

Pozor! Užívajte pouze baktericidný a fungicidný sanitárny silikón.

Внимание! Применяйте только антибактериальные силиконовые герметики с фунгицидом

Cuidado! Utilizar solamente silicona sanitaria bactericida y fungicida.

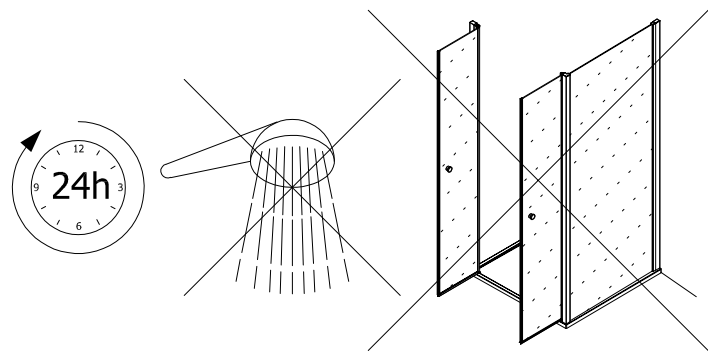

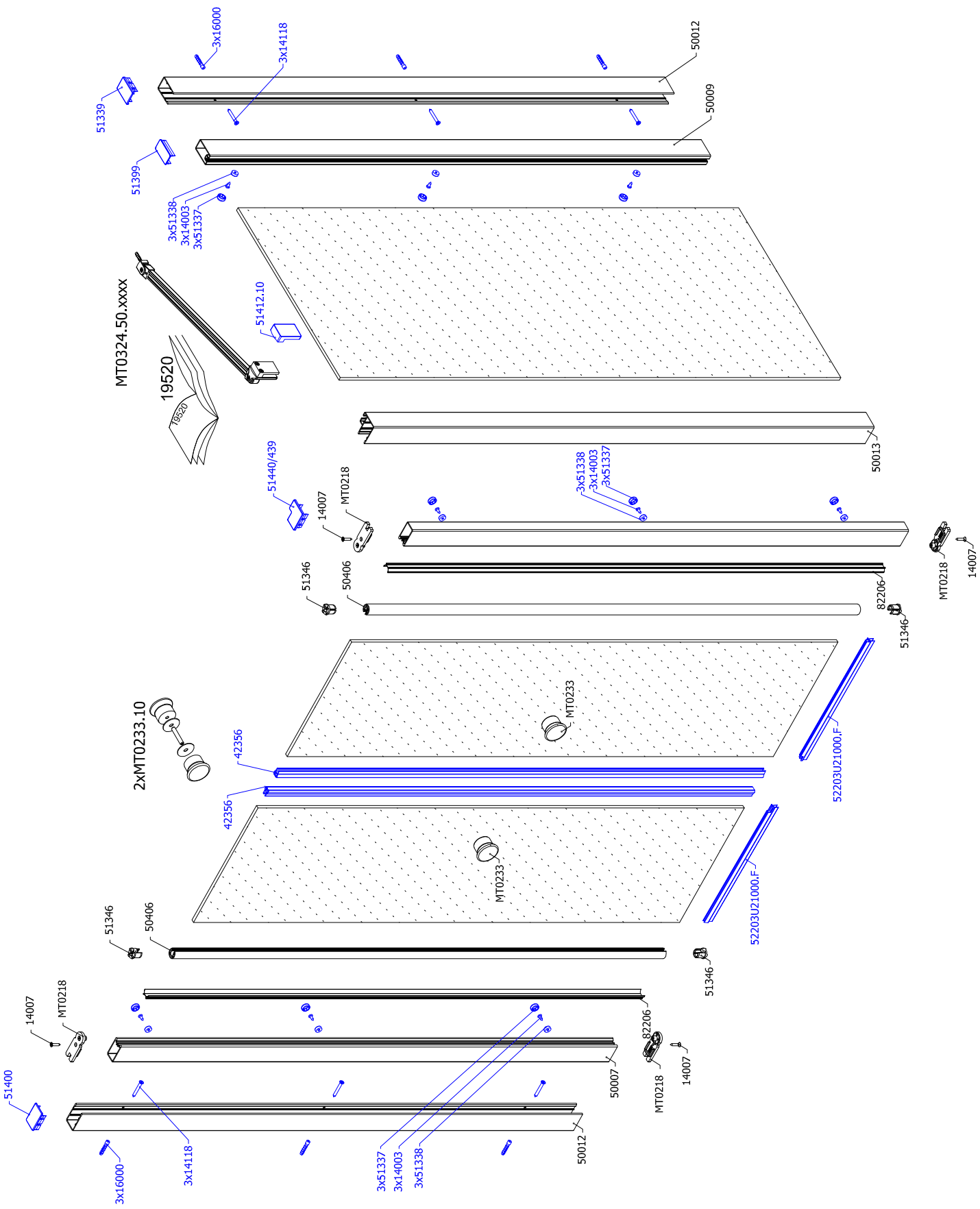

Benötigtes Werkzeug:
 Necessary tools:
 Outil Nécessaire:
 Nářadí potřebné pro montáž:
 Potrzebne narzędzia:
 Potrebne náradie:
 необходимые инструменты:
 Herramientas necesarias:

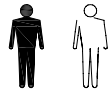

1x

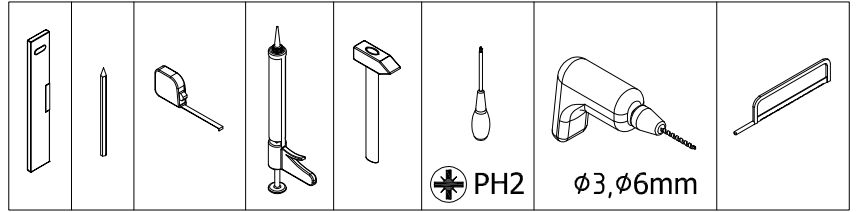

PH2

Ø3, Ø6mm

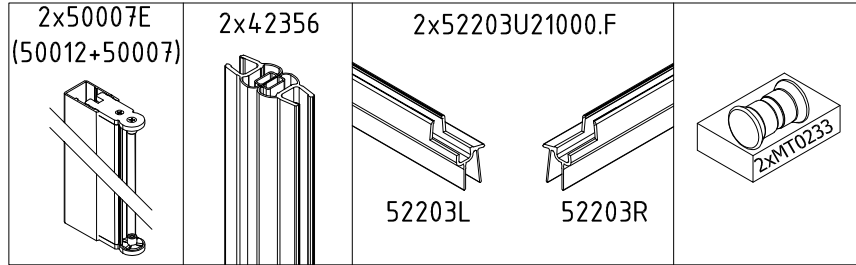
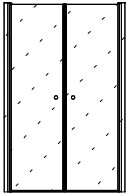

Zubehör:
 Equipment:
 Accessoires:
 Příslušenství:
 Dodatki:
 Príslušenstvo:
 Аксессуары:
 Accesorios:

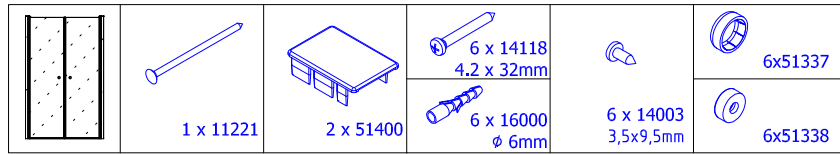

10.

2x50007E
(50012+50007)

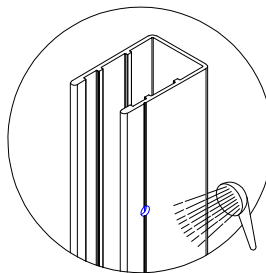
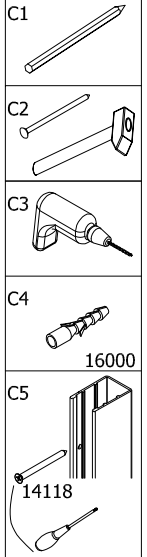
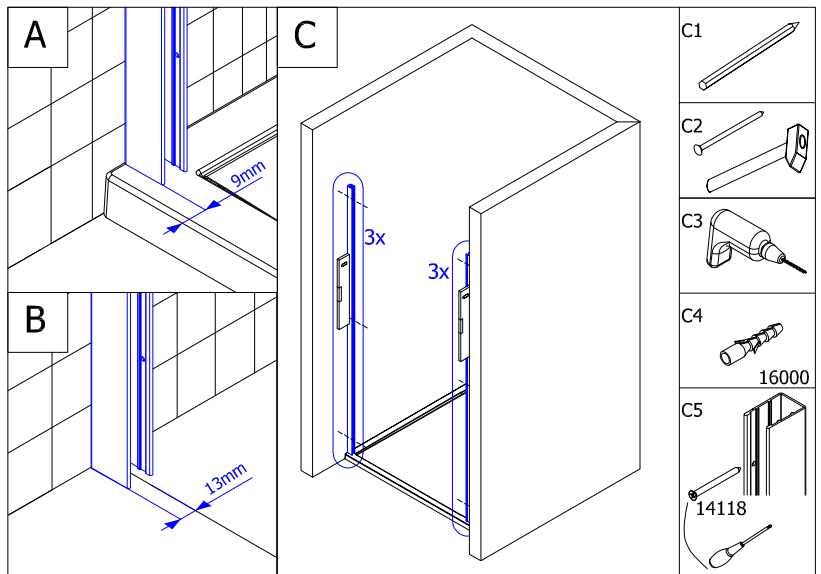
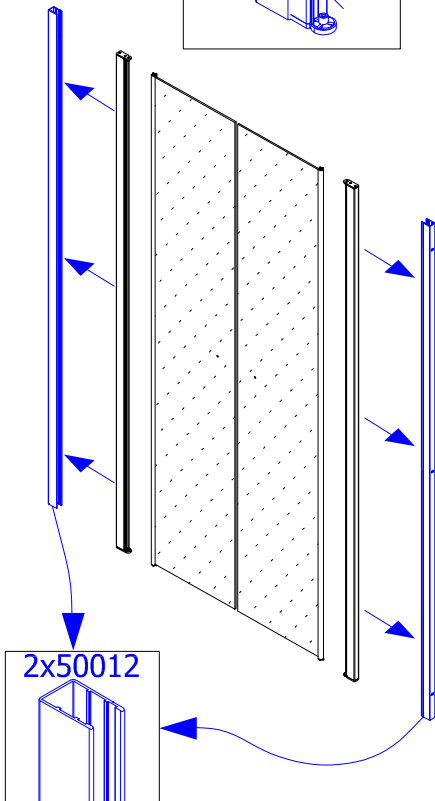
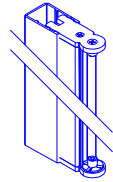

11.

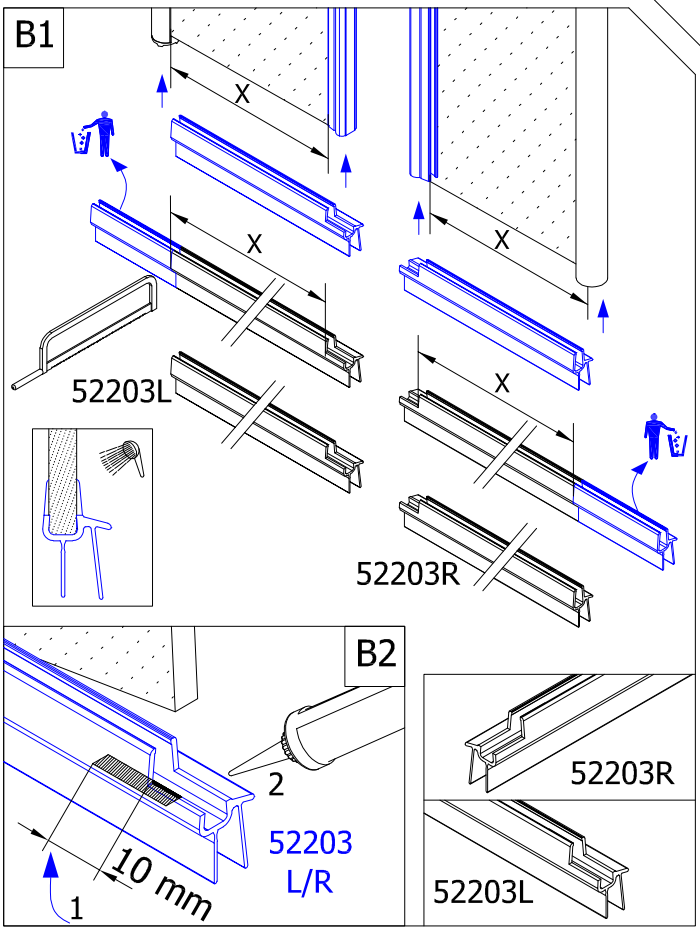
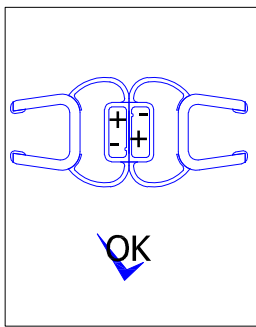
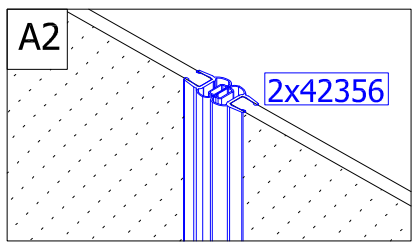
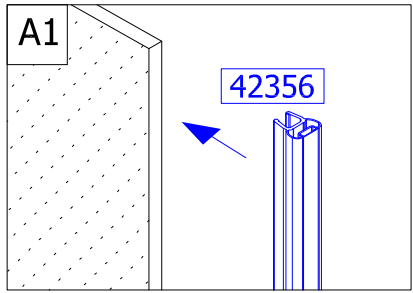
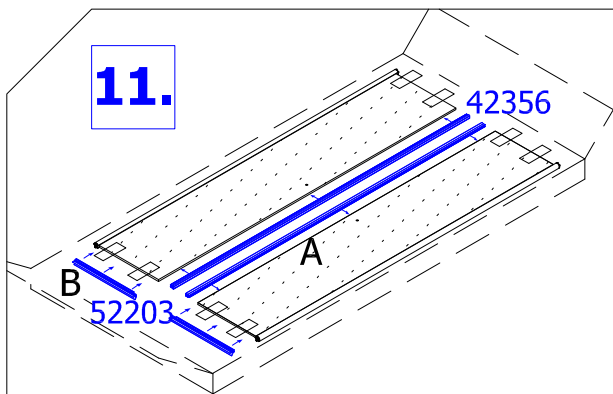

12.

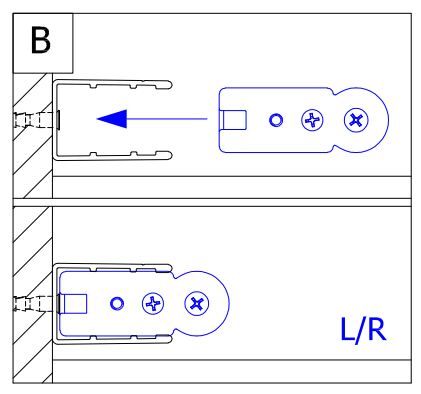
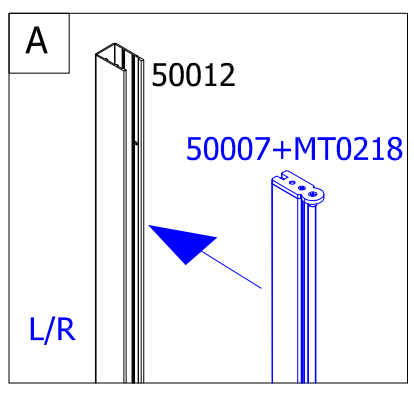
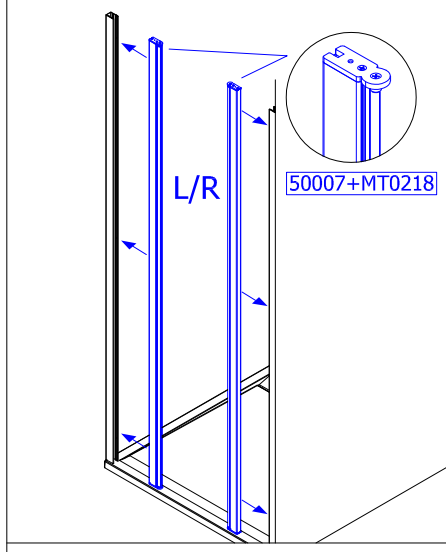

13.

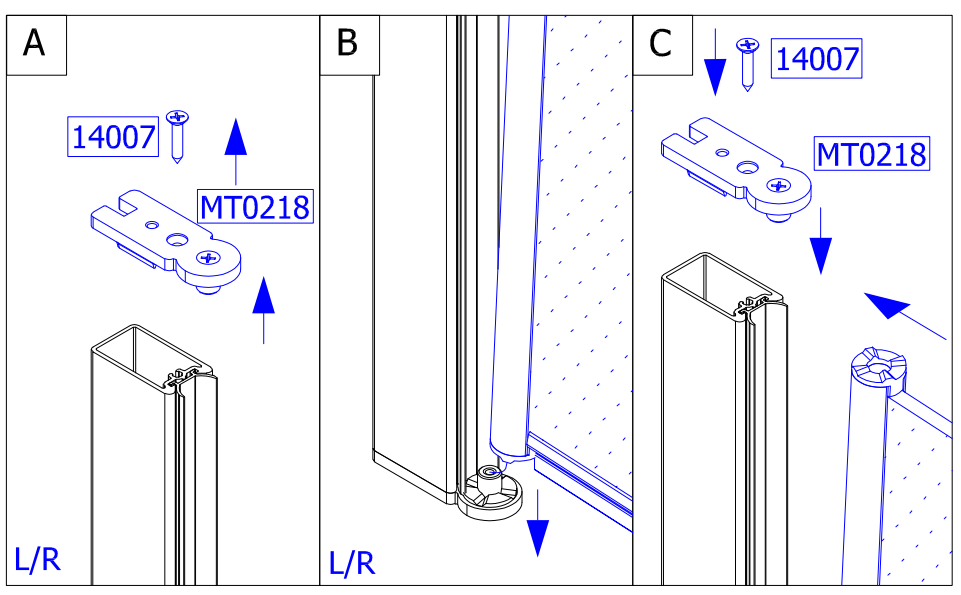
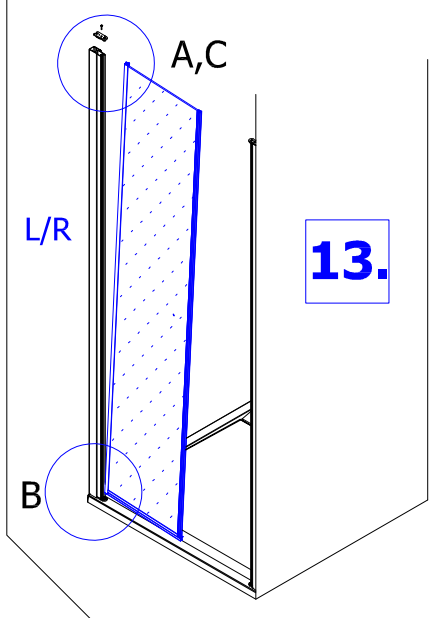

14.

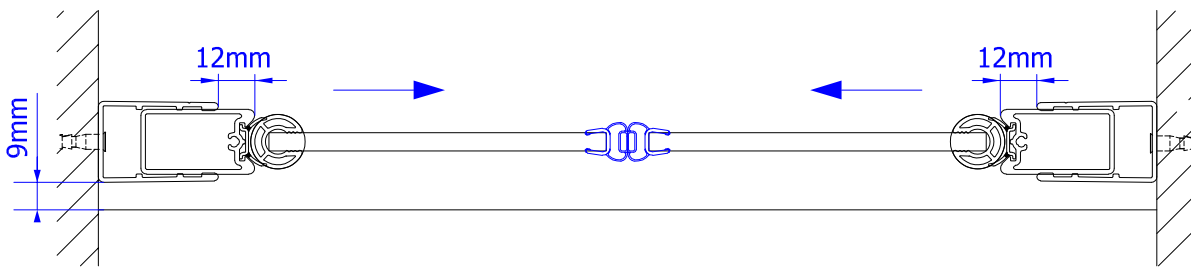

15.

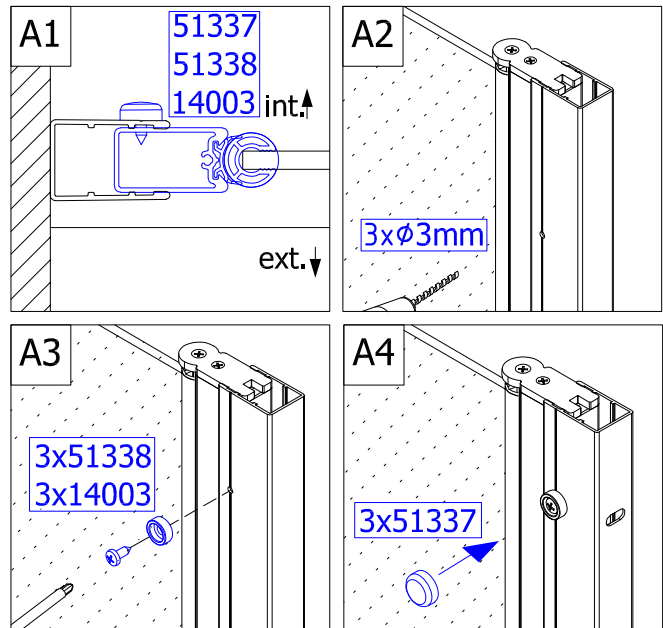
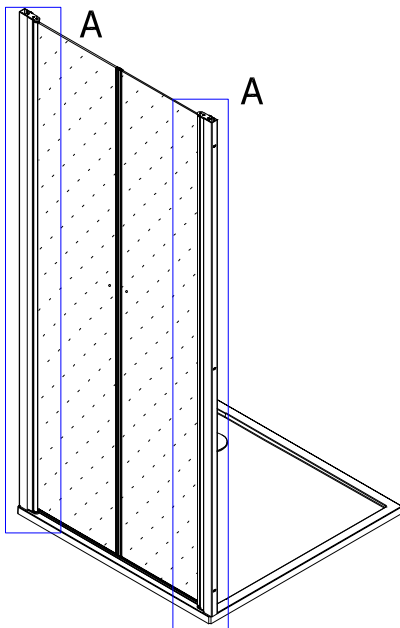

16.

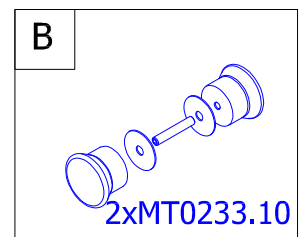
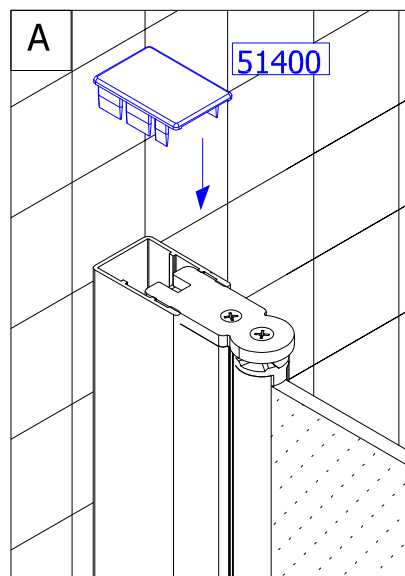
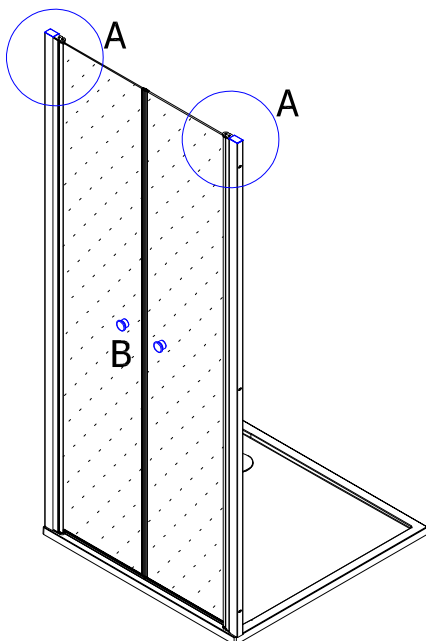

17.

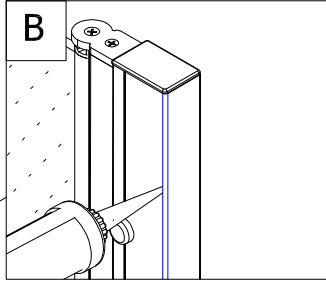
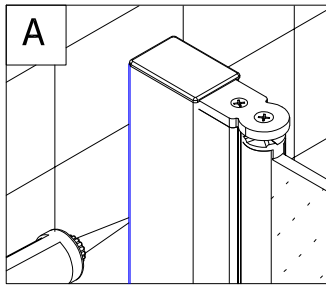
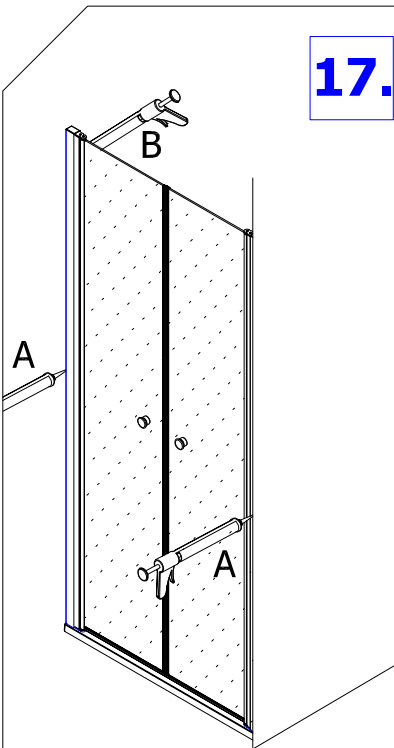

Achtung! Nur Sanitär-Silikon - bakterizid und fungizid eingestellt verwenden.

Caution! Use only bactericidal and fungicide sanitary silicone.

Attention! N'utiliser que du silicone sanitaire bactéricide et fongicide.

Pozor! Používejte pouze baktericidní a fungicidní sanitární silikon.

Uwaga! Stosować tylko silikon sanitarny - bakterio i grzybobójczy.

Pozor! Užívajte pouze baktericidný a fungicidný sanitárny silikón.

Внимание! Применяйте только антибактериальные силиконовые герметики с фунгицидом

Cuidado! Utilizar solamente silicona sanitaria bactericida y fungicida.

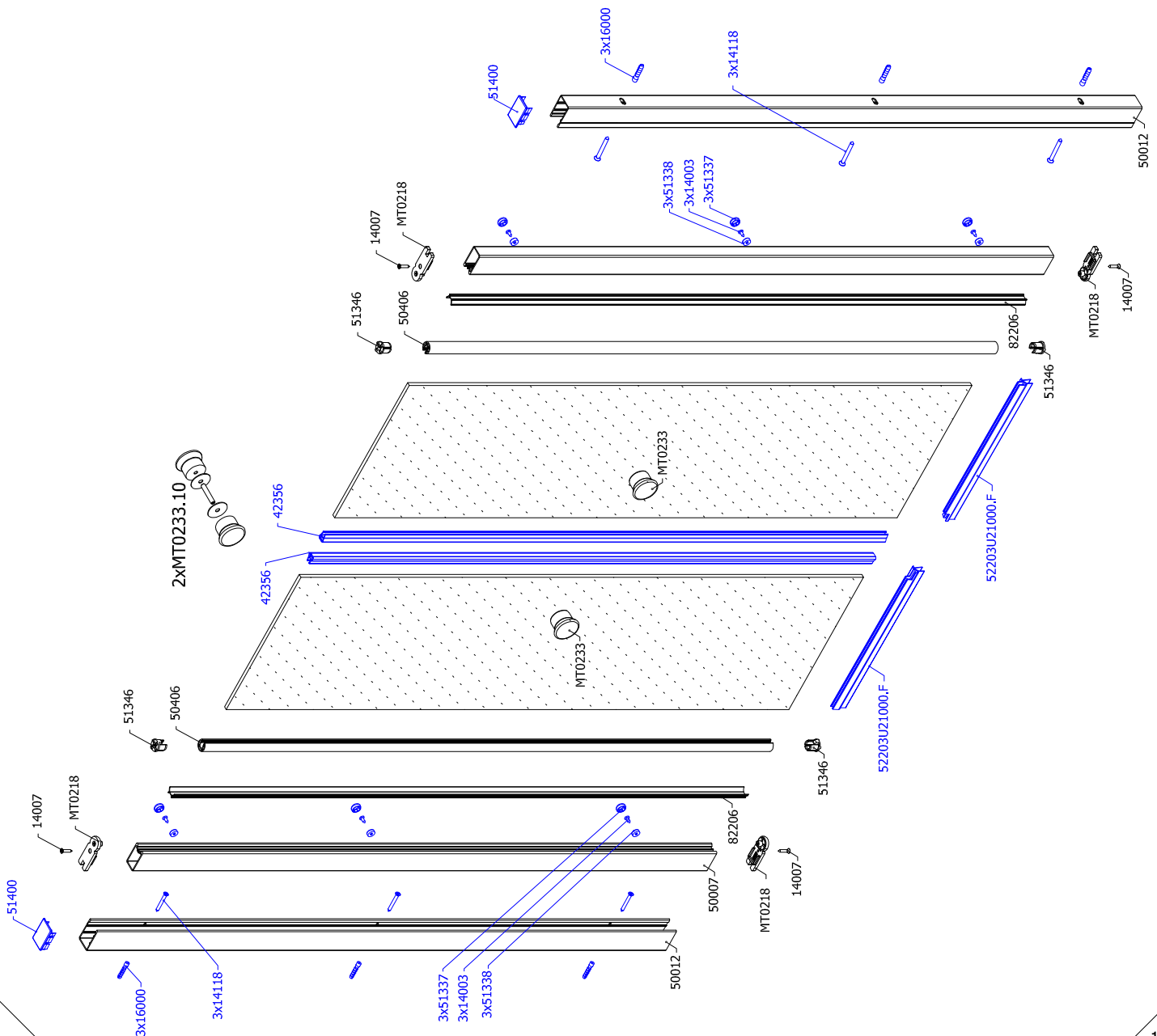
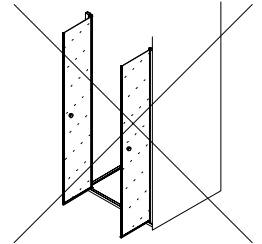
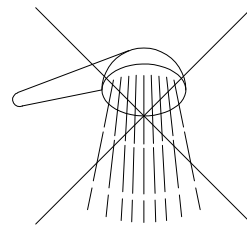

QUALITY CONTROL:

- DE** Dieses Produkt wurde unter sorgfältiger Beachtung der Qualitäts-Richtlinien gefertigt und vor dem Verpacken einer eingehenden Prüfung unterzogen. Sollten Sie dennoch einen Produktmangel oder eine Beschädigung feststellen, so setzen Sie sich bitte direkt mit der Firma in Verbindung, bei der Sie dieses Produkt gekauft haben.
- GB** This product was made with careful attention to quality guidelines and was subjected to a thorough examination before packaging. However, if you find a product defect or damage so please get in touch directly with the company in which you have bought this product.
- FR** Ce produit est fabriqué avec une attention particulière selon des normes de qualité et est soumis à un contrôle approfondi avant l'emballage. Toutefois, si le produit présente un défaut ou un dommage, veuillez prendre contact avec l'entreprise qui vous a vendu ce produit.
- CZ** Tento produkt byl vyroben s odbornou péčí podle příslušných kvalitativních směrnic a před zabalením byl důkladně zkontrolován. Pokud u něho přesto zjistíte závadu nebo poškození, kontaktujte prosím firmu, u které jste výrobek zakoupili.
- PL** Produkt ten został wyprodukowany z uwzględnieniem rygorystycznych norm jakościowych, a następnie podany drobiazgowej kontroli przed zapakowaniem. Jeżeli po rozpakowaniu (przed rozpoczęciem montażu!) stwierdzicie Państwo wady lub uszkodzenia to prosimy o natychmiastowe zgłoszenie tego faktu sprzedawcy.
- SK** Tento produkt bol vyrobený s odbornou starostlivosťou podľa príslušných kvalitatívnych smerníc a pred zabalením bol dôkladne skontrolovaný. Ak u neho aj napriek tomu zistíte závadu alebo poškodenie, kontaktujte prosím firmu, u ktorej ste výrobok zakúpili.
- RU** Это изделие было изготовлено с особым вниманием в соответствии с высокими стандартами качества и было тщательно проверено перед упаковкой. В то же время, если вы обнаружите дефект или повреждение, обратитесь в компанию, у которой вы купили это изделие.
- ES** Este producto ha sido fabricado cumpliendo estrictamente las normativas de calidad y ha sido sometido a un control exhaustivo antes de embalarlo. En caso de que a pesar de ello, Usted note algún desperfecto del producto, rogamos se ponga en contacto directamente con la empresa donde haya comprado el producto.
- RO** Acest produs a fost fabricat respectând cele mai stricte norme de calitate, iar produsul a fost testat înainte de a fi împachetat. Dacă totuși observați o neregulă sau o defectiune, vă rugăm să contactați direct firma de la care ați achiziționat produsul.

.....

.....

.....

.....

.....

.....