

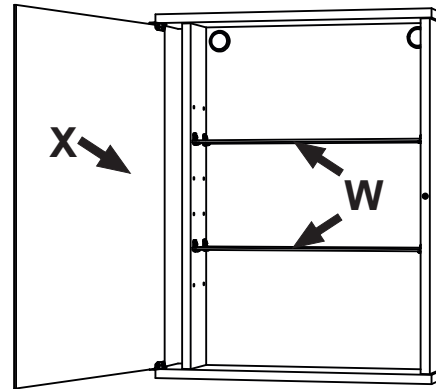

- DE Scharnierschrauben nach ca. 2 Wochen und dann 1 x jährlich auf festen Sitz prüfen und nachziehen!  
 GB Please retight the hinge screws after 14 days and then once a year!  
 FR Veuillez resserrer les vis de charnière après 14 jours, puis une fois par an !  
 NL Draai de scharnierschroeven a.u.b. na 14 dagen en daarna eenmaal per jaar weer vast!  
 IT Si prega di riavvitare le viti della cerniera dopo 14 giorni e poi una volta all'anno!  
 ES ¡Vuelva a apretar los tornillos de la bisagra después de 14 días y luego una vez al año!  
 PT Por favor, reaperte os parafusos da dobradiça após 14 dias e depois uma vez por ano!  
 CZ Po 14 dnech a poté jednou ročně dotáhněte šrouby závěsu!  
 PL Proszę ponownie dokręcić śruby zawiasów po 14 dniach, a następnie raz w roku!  
 HU Kérjük, 14 nap után, majd évente egyszer húzza meg a zsanérszavarokat!  
 SI Po 14 dneh ponovno privijte vijake tečajev in nato enkrat letno!  
 HR Ponovo zategnite vijke šarki nakon 14 dana, a zatim jednom godišnje!  
 SK Po 14 dňoch a potom raz za rok dotiahnite skrutky závesu!  
 BH Molimo zategnite zavrtnje šarki nakon 14 dana, a zatim jednom godišnje!  
 BG Моля, затегнете отново винтовете на пантите след 14 дни и след това веднъж годишно!  
 RO Vă rugăm să strângeți din nou șuruburile balamalei după 14 zile și apoi o dată pe an!  
 SE Dra åt gångjärnsskruvarna igen efter 14 dagar och sedan en gång om året!  
 DK Efterspænd hængselskruerne efter 14 dage og derefter en gang om året!  
 IS Vinsamlega skrufið lömskrúfurmar aftur eftir 14 daga og síðan einu sinni á ári!  
 FI Kiristä saranaruuvit uudelleen 14 päivän kuluttua ja sen jälkeen kerran vuodessa!  
 EST Pingutage hinge kruvid uuesti 14 päeva pärast ja seejärel kord aastas!  
 TR Lütfen menteşe vidalarnı 14 gün sonra ve ardından yılda bir kez tekrar sıkın!  
 GR Ξαναβιδώστε τις μεντεσέδες μετά από 14 ημέρες και μετά μία φορά το χρόνο!

## ERSATZTEILE / SPARE PARTS

FR Pièces d'échange	CZ Náhradní díly	SK Náhradné diely	DK Reservedele
NL Onderdelen	PL Części zamienne	BH Rezervni dijelovi	IS Auka hlutir
IT Pezzi ricambio	HU Tartalék részek	BG Резервни части	FI Varaosat
ES Piezas de recambio	SI Rezervni deli	RO Piese de schimb	EST Varuosad
PT Peças sobresselentes	HR Pričuvni dijelovi	SE Reservdelar	TR Yedek parçalar
			GR Ανταλλακτικά



## SERVICE

- DE Bei Reklamationen diesen Abschnitt (Kopie) **zusammen mit dem Kaufbeleg** an Jokey schicken.  
 GB In the event of a complaint, send this section (copy) **together with the purchase receipt** to Jokey.  
 FR En cas de réclamation, envoyez cette section (copie) **avec le reçu d'achat** à Jokey.  
 NL Stuur bij een klacht deze rubriek (kopie) **samen met de aankoopbon** naar Jokey.  
 IT In caso di reclamo, inviare questa sezione (copia) **insieme alla ricevuta di acquisto** a Jokey.  
 ES En caso de queja, envíe esta sección (copia) **junto con el recibo de compra** a Jokey.  
 PT Em caso de reclamação, envie esta seção (cópia) **junto com o comprovante de compra** para Jokey.  
 CZ V případě reklamace zašlete tento oddíl (kopii) **spolu s účtenkou o koupi** společnosti Jokey.  
 PL W przypadku reklamacji wyślij ten dział (kopia) **wraz z dowodem zakupu** do Jokey.  
 HU Reklamáció esetén ezt a részt (másolat) **a vásárlási bizonylattal együtt küldje** el a Jokey-nak.  
 SI V primeru reklamacije pošljite ta razdelek (kopijo) **skupaj s potrdilom o nakupu** na Jokey.  
 HR U slučaju reklamacije, pošaljite ovaj odjeljak (kopiju) **zajedno s potvrdom o kupnji** Jokeyju.  
 SK V prípade reklamácie zašlite túto časť (kópiu) **spolu s dokladom o kúpe** spoločnosti Jokey.  
 BH U slučaju reklamacije, pošaljite ovaj odjeljak (kopiju) **zajedno s računom o kupovini** Jokeyju.  
 BG В случай на reclamaция, изпратете този раздел (копие) **заедно с разписката за покупка** на Jokey.  
 RO În cazul unei reclamații, trimiteți această secțiune (copie) **împreună cu chitanța de cumpărare** către Jokey.  
 SE Vid reklamation skicka detta avsnitt (kopia) **tillsammans med köpkvittot** till Jokey.  
 DK Ved reklamation sendes dette afsnit (kopi) **sammen med købskvittering** til Jokey.  
 IS Komi til kvörtunark skal senda þennan hluta (afrit) **ásamt kaupkvittun** til Jokey.  
 FI Jos sinulla on reklamaatio, lähetä tämä osa (kopio) **ostokuitin kanssa** Jokeylle.  
 EST Käebuste korral saada see jaotis (koopia) koos ostutõendiga Jokeyle.  
 TR Şikayet durumunda bu bölümü (kopyasını) **satın alma makbuzu ile birlikte** Jokey'e gönderin.  
 GR Σε περίπτωση καταγγελίας, στείλετε αυτό το τμήμα (αντίγραφο) **μαζί με την απόδειξη αγοράς** στο Jokey.

QS

→ Jokey Service

430714405







111912100 ENTROBEL 50 ohne Elektrik 08 / 2022

Jokey Sohland GmbH Service Industriestr. 4 D - 02689 Sohland / Spree  
 Tel.: +49(0)35936 / 36-0 Tel. Service: +49(0)35936 / 36-2265 email: js.service@jokey.com  
 Fax: +49(0)35936 / 36-2222 Fax Service: +49(0)35936 / 36-2281 http://www.jokey-online.com



ENTROBEL 50  
111912100



<b>A</b>	2 x	
<b>B</b>	2 x	
<b>C</b>	2 x	
<b>D</b>	2 x	
<b>E</b>	2 x	
<b>F</b>	8 x	
<b>G</b>	1 x	